

Version :1.1

TECHNICAL SPECIFICATION

MODEL NO. : PD035VX2

Customer's Confirmation

Customer _____

By _____

PVI's Confirmation

Confirmed By _____

Prepared By _____

PRIME VIEW INTERNATIONAL CO.,LTD.
3,LI SHIN RD. 1,SCIENCE-BASED INDUSTRIAL
PARK,HSINCHU,TAIWAN,R.O.C.
<http://www.pvi.com.tw>

Date: Apr. 20 , 2005

This technical specification is subject to change without notice.
Please return 1 copy with your signature on this page for approval.

TECHNICAL SPECIFICATION**CONTENTS**

<i>NO.</i>	<i>ITEM</i>	<i>PAGE</i>
-	Cover	1
-	Contents	2
1	Application	3
2	Features	3
3	Mechanical Specifications	3
4	Mechanical Drawing of TFT-LCD module	4
5	Input / Output Terminals	5
6	Absolute Maximum Ratings	10
7	Electrical Characteristics	10
8	Pixel Arrangement	11
9	Display Color and Gray Scale Reference	12
10	Block Diagram	13
11	Interface Timing	14
12	Power On Sequence	19
13	Optical Characteristics	19
14	Handling Cautions	23
15	Reliability Test	24
16	Packing	25
-	Revision History	27
-	Appendix	28

1. Application

This data sheet applies to a color TFT LCD module , PD035VX2.

It applies to projector , and other media application which require high quality flat panel display.

2. Features

- . Amorphous silicon TFT LCD panel
- . Pixel in stripe configuration
- . Display Colors : 262,144 colors
- . Optimum Viewing Direction : 6 o'clock
- . TTL transmission interface

3. Mechanical Specifications

Parameter	Specifications	Unit
Screen Size	3.5 (diagonal)	inch
Display Format	640×(R, G, B)×480	dot
Display Colors	262,144	
Active Area	72 (H)×52.56 (V)	mm
Pixel Pitch	0.1125 (H)×0.1095 (V)	mm
Pixel Configuration	Stripe	
Outline Dimension	84.25 (W)×65.40 (H)×3.45 (D) (Typ.)	mm
Weight	40±5	g
Surface treatment	AG	
Display mode	Normally white	

4.Mechanical Drawing of TFT-LCD Module

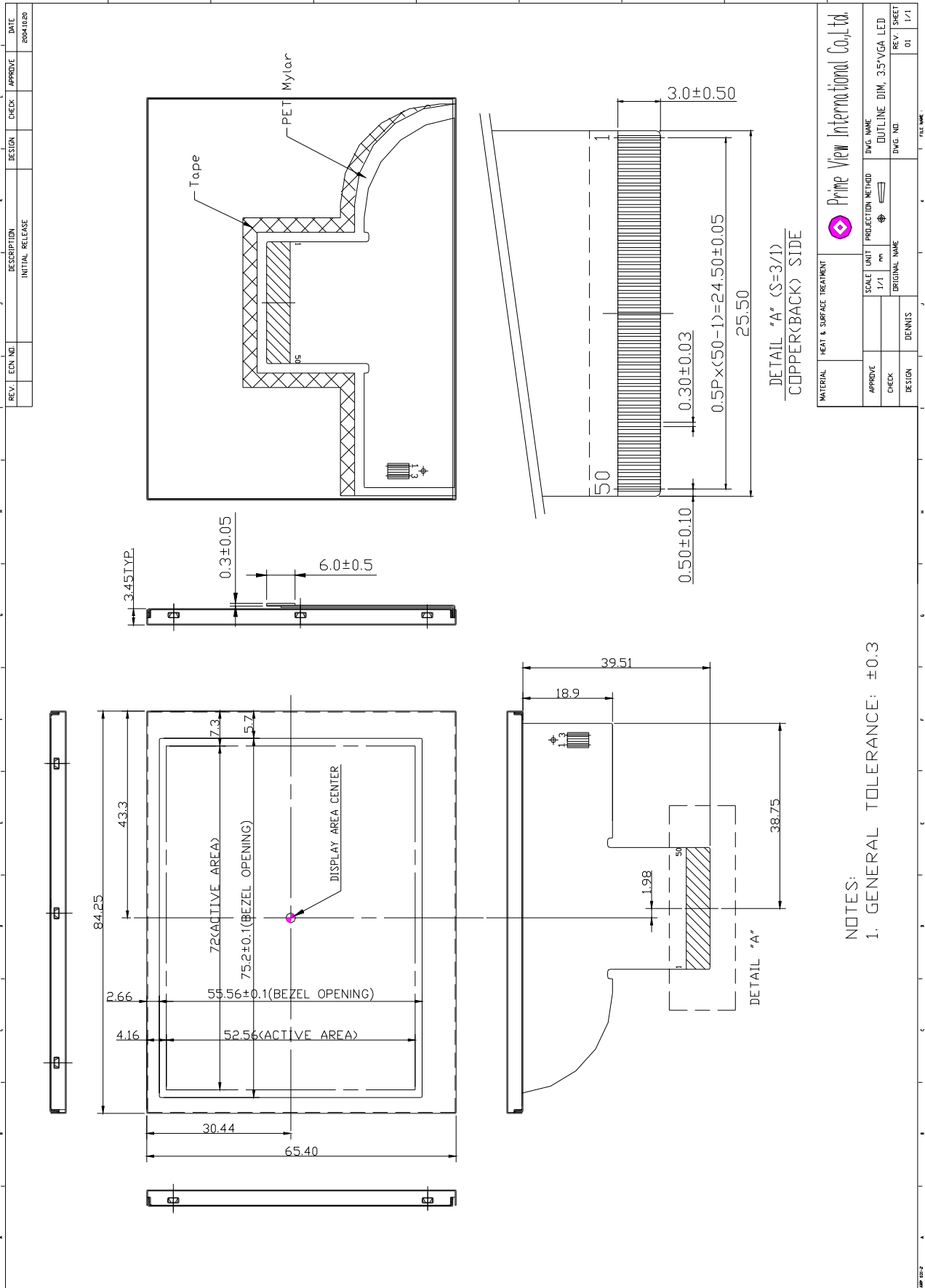

REV.	ECN NO.	DESCRIPTION	DESIGN	CHECK	APPROVE	DATE
		INITIAL RELEASE				2004.10.20

MATERIAL	HEAT & SURFACE TREATMENT	PROJECTION METHOD	SCALE	UNIT	PROJECTION METHOD	DWG. NAME
			1/1	mm		OUTLINE DIM. 35"VGA LED
APPROVE	CHECK	DESIGN	DESIGN	DESIGN	DESIGN	DWG. NO.
						REV. SHEET
						01
						1/1

Prime View International Co., Ltd.

NOTES:
1. GENERAL TOLERANCE: ±0.3

5.Input / Output Terminals
TFT-LCD Panel Driving

Pin No.	Symbol	I/O	Function	Remark
1	DIO1	I/O	Horizontal Start Pulse Signal Input or Output 1	Note5-1
2	VSS2	I	Ground	
3	VDD1	I	Power Supply	
4	CLK	I	Horizontal Shift Clock	
5	R/L	I	Left/Right Selection	Note 5-1
6	R0	I	Red Data (LSB)	
7	R1	I	Red Data	
8	R2	I	Red Data	
9	R3	I	Red Data	
10	R4	I	Red Data	
11	R5	I	Red Data (MSB)	
12	VSS2	I	Ground	
13	G0	I	Green Data (LSB)	
14	G1	I	Green Data	
15	G2	I	Green Data	
16	G3	I	Green Data	
17	G4	I	Green Data	
18	G5	I	Green Data (MSB)	
19	B0	I	Blue Data (LSB)	
20	B1	I	Blue Data	
21	B2	I	Blue Data	
22	B3	I	Blue Data	
23	B4	I	Blue Data	
24	B5	I	Blue Data (MSB)	
25	LD	I	Load output signal	Note5-2
26	REV	I	Data invert control	Note5-3
27	POL	I	Polarity selection	Note5-4
28	DIO2	I/O	Horizontal Start Pulse Signal Input or Output	Note5-1
29	VSS2	I	Ground	
30	V3	I	Gamma Voltage 3	Note5-5
31	V5	I	Gamma Voltage 5	Note5-5
32	V7	I	Gamma Voltage 7	Note5-5
33	V8	I	Gamma Voltage 8	Note5-5
34	V10	I	Gamma Voltage 10	Note5-5
35	V12	I	Gamma Voltage 12	Note5-5
36	VSS2	I	Ground	
37	VDD2	I	Voltage for analog circuit	Note5-5
38	VCOM	I	Common Voltage	
39	OE	I	Output Enable	Note5-6
40	U/D	I	Up/Down Selection	Note 5-7
41	CKV	I	Vertical Shift Clock	Note5-8
42	STVU	I/O	Vertical Shift Pulse Signal Input or Output	Note5-7
43	STVD	I/O	Vertical Shift Pulse Signal Input or Output	Note5-7
44	VGG	I	Gate On Voltage	Note5-9
45	VSS1	I	Ground	
46	VCC	I	Voltage for logic circuit	
47	VEE	I	Gate Off Voltage	Note5-10
48	VLED	-	Supply voltage for LED backlight	Note5-11
49	GLED2	-	Ground for LED backlight	
50	GLED1	-	Ground for LED backlight	

Note 5-1: Select left or right shift

R/L	DIO1	DIO2	Shift
1	Input	HiZ	Left to right
0	HiZ	Input	Right to left

Note 5-2: Latch the polarity of outputs and switch the new data to outputs

At the rising edge (LD), latch the “POL” signal to control the polarity of the outputs.

Note 5-3: Control whether the Data R0~G5 are inverted or not. (PVI suggests connecting to GND)

When “REV=1”, these data will be inverted.

EX: “00”→”3F”, “07”→”38”, “15”→”2A”

Note 5-4: Polarity selector for dot-inversion control. Available at the rising edge of LD.

When POL=1: Even outputs range from V1~V7, and Odd outputs range from V8~V14;

When POL=0: Even outputs range from V8~V14, and Odd outputs range from V1~V7.

Note 5-5:

1) Relationship between input data and output voltage

The figure below shows the relationship between the input data and the output voltage with the polarity. The range of V1~V7 is for positive polarity, and V8~V14 for negative polarity. Please refer to the following pages to get the related resistor values and voltage calculation method.

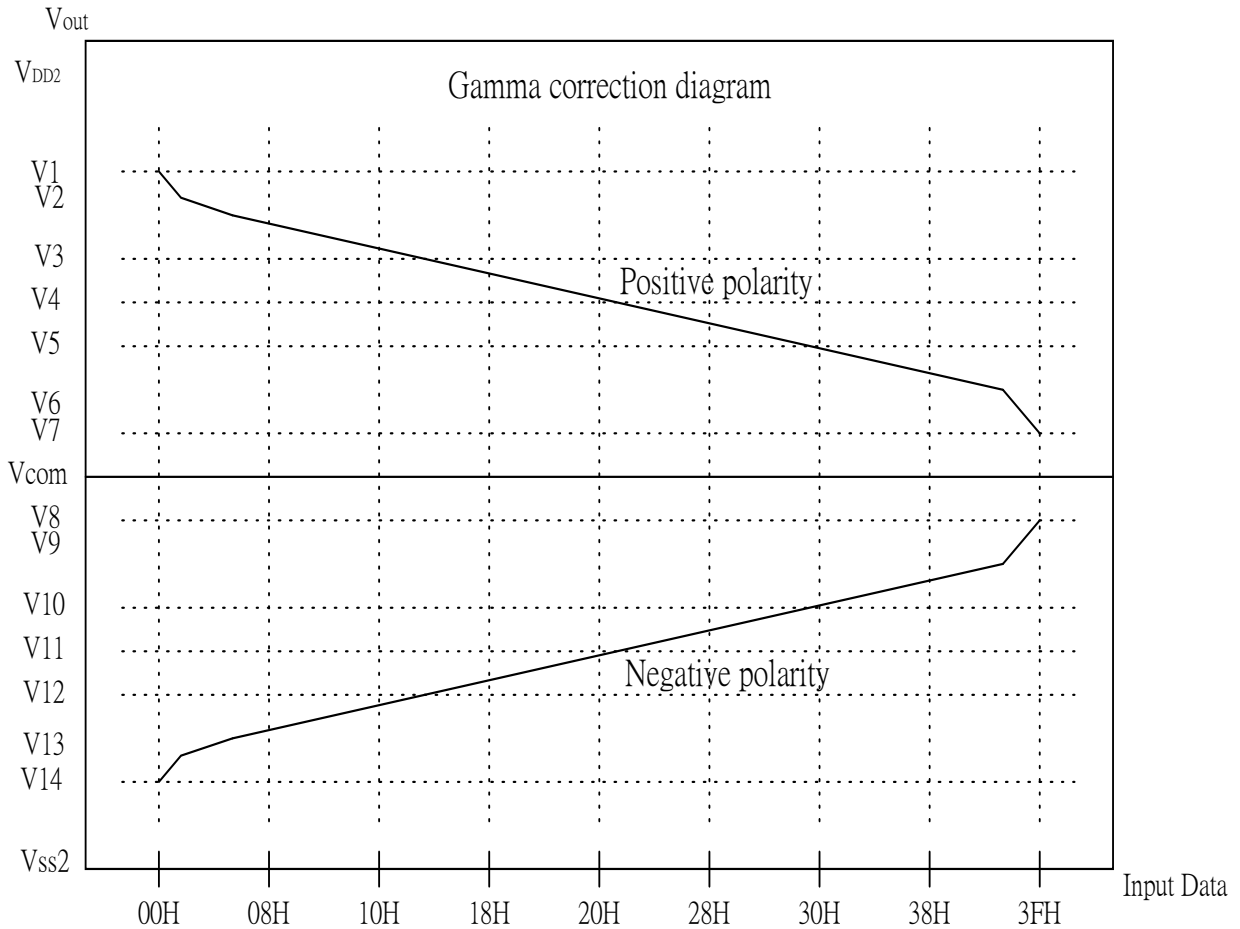

1. Output voltage and input data
Output Voltage to Panel VS Input Data

Data	Positive polarity Output Voltage	Negative polarity Output Voltage
00H	V1	V14
01H	$V2=V3+(V1-V3) \times 58 / 64.4$	$V13=V14+(V12-V14) \times 6.4 / 64.4$
02H	$V3+(V1-V3) \times 52 / 64.4$	$V14+(V12-V14) \times 12.4 / 64.4$
03H	$V3+(V1-V3) \times 46.4 / 64.4$	$V14+(V12-V14) \times 18 / 64.4$
04H	$V3+(V1-V3) \times 41.2 / 64.4$	$V14+(V12-V14) \times 23.2 / 64.4$
05H	$V3+(V1-V3) \times 36.4 / 64.4$	$V14+(V12-V14) \times 28 / 64.4$
06H	$V3+(V1-V3) \times 32 / 64.4$	$V14+(V12-V14) \times 32.4 / 64.4$
07H	$V3+(V1-V3) \times 27.6 / 64.4$	$V14+(V12-V14) \times 36.8 / 64.4$
08H	$V3+(V1-V3) \times 23.6 / 64.4$	$V14+(V12-V14) \times 40.8 / 64.4$
09H	$V3+(V1-V3) \times 19.6 / 64.4$	$V14+(V12-V14) \times 44.8 / 64.4$
0AH	$V3+(V1-V3) \times 16.4 / 64.4$	$V14+(V12-V14) \times 48 / 64.4$
0BH	$V3+(V1-V3) \times 13.2 / 64.4$	$V14+(V12-V14) \times 51.2 / 64.4$
0CH	$V3+(V1-V3) \times 10.4 / 64.4$	$V14+(V12-V14) \times 54 / 64.4$
0DH	$V3+(V1-V3) \times 7.6 / 64.4$	$V14+(V12-V14) \times 56.8 / 64.4$
0EH	$V3+(V1-V3) \times 4.8 / 64.4$	$V14+(V12-V14) \times 59.6 / 64.4$
0FH	$V3+(V1-V3) \times 2.4 / 64.4$	$V14+(V12-V14) \times 62 / 64.4$
10H	V3	V12
11H	$V4+(V3-V4) \times 19.6 / 22$	$V12+(V11-V12) \times 2.4 / 22$
12H	$V4+(V3-V4) \times 17.6 / 22$	$V12+(V11-V12) \times 4.4 / 22$
13H	$V4+(V3-V4) \times 15.6 / 22$	$V12+(V11-V12) \times 6.4 / 22$
14H	$V4+(V3-V4) \times 13.6 / 22$	$V12+(V11-V12) \times 8.4 / 22$
15H	$V4+(V3-V4) \times 12 / 22$	$V12+(V11-V12) \times 10 / 22$
16H	$V4+(V3-V4) \times 10.4 / 22$	$V12+(V11-V12) \times 11.6 / 22$
17H	$V4+(V3-V4) \times 8.8 / 22$	$V12+(V11-V12) \times 13.2 / 22$
18H	$V4+(V3-V4) \times 7.6 / 22$	$V12+(V11-V12) \times 14.4 / 22$
19H	$V4+(V3-V4) \times 6.4 / 22$	$V12+(V11-V12) \times 15.6 / 22$
1AH	$V4+(V3-V4) \times 5.2 / 22$	$V12+(V11-V12) \times 16.8 / 22$
1BH	$V4+(V3-V4) \times 4 / 22$	$V12+(V11-V12) \times 18 / 22$
1CH	$V4+(V3-V4) \times 3.2 / 22$	$V12+(V11-V12) \times 18.8 / 22$
1DH	$V4+(V3-V4) \times 2.4 / 22$	$V12+(V11-V12) \times 19.6 / 22$
1EH	$V4+(V3-V4) \times 1.6 / 22$	$V12+(V11-V12) \times 20.4 / 22$
1FH	$V4+(V3-V4) \times 0.8 / 22$	$V12+(V11-V12) \times 21.2 / 22$

Output Voltage to Panel VS Input Data(continued)

Data	Positive polarity Output Voltage	Negative polarity Output Voltage
20H	V4	V11
21H	$V5+(V4-V5) \times 12 / 12.8$	$V11+(V10-V11) \times 0.8 / 12.8$
22H	$V5+(V4-V5) \times 11.2 / 12.8$	$V11+(V10-V11) \times 1.6 / 12.8$
23H	$V5+(V4-V5) \times 10.4 / 12.8$	$V11+(V10-V11) \times 2.4 / 12.8$
24H	$V5+(V4-V5) \times 9.6 / 12.8$	$V11+(V10-V11) \times 3.2 / 12.8$
25H	$V5+(V4-V5) \times 8.8 / 12.8$	$V11+(V10-V11) \times 4 / 12.8$
26H	$V5+(V4-V5) \times 8 / 12.8$	$V11+(V10-V11) \times 4.8 / 12.8$
27H	$V5+(V4-V5) \times 7.2 / 12.8$	$V11+(V10-V11) \times 5.6 / 12.8$
28H	$V5+(V4-V5) \times 6.4 / 12.8$	$V11+(V10-V11) \times 6.4 / 12.8$
29H	$V5+(V4-V5) \times 5.6 / 12.8$	$V11+(V10-V11) \times 7.2 / 12.8$
2AH	$V5+(V4-V5) \times 4.8 / 12.8$	$V11+(V10-V11) \times 8 / 12.8$
2BH	$V5+(V4-V5) \times 4 / 12.8$	$V11+(V10-V11) \times 8.8 / 12.8$
2CH	$V5+(V4-V5) \times 3.2 / 12.8$	$V11+(V10-V11) \times 9.6 / 12.8$
2DH	$V5+(V4-V5) \times 2.4 / 12.8$	$V11+(V10-V11) \times 10.4 / 12.8$
2EH	$V5+(V4-V5) \times 1.6 / 12.8$	$V11+(V10-V11) \times 11.2 / 12.8$
2FH	$V5+(V4-V5) \times 0.8 / 12.8$	$V11+(V10-V11) \times 12 / 12.8$
30H	V5	V10
31H	$V7+(V5-V7) \times 26.8 / 27.6$	$V10+(V8-V10) \times 0.8 / 27.6$
32H	$V7+(V5-V7) \times 26 / 27.6$	$V10+(V8-V10) \times 1.6 / 27.6$
33H	$V7+(V5-V7) \times 25.2 / 27.6$	$V10+(V8-V10) \times 2.4 / 27.6$
34H	$V7+(V5-V7) \times 24.4 / 27.6$	$V10+(V8-V10) \times 3.2 / 27.6$
35H	$V7+(V5-V7) \times 23.6 / 27.6$	$V10+(V8-V10) \times 4 / 27.6$
36H	$V7+(V5-V7) \times 22.4 / 27.6$	$V10+(V8-V10) \times 5.2 / 27.6$
37H	$V7+(V5-V7) \times 21.2 / 27.6$	$V10+(V8-V10) \times 6.4 / 27.6$
38H	$V7+(V5-V7) \times 20 / 27.6$	$V10+(V8-V10) \times 7.6 / 27.6$
39H	$V7+(V5-V7) \times 18.4 / 27.6$	$V10+(V8-V10) \times 9.2 / 27.6$
3AH	$V7+(V5-V7) \times 16.8 / 27.6$	$V10+(V8-V10) \times 10.8 / 27.6$
3BH	$V7+(V5-V7) \times 14.8 / 27.6$	$V10+(V8-V10) \times 12.8 / 27.6$
3CH	$V7+(V5-V7) \times 12.8 / 27.6$	$V10+(V8-V10) \times 14.8 / 27.6$
3DH	$V7+(V5-V7) \times 10.4 / 27.6$	$V10+(V8-V10) \times 17.2 / 27.6$
3EH	$V7+(V5-V7) \times 6.4 / 27.6$	$V10+(V8-V10) \times 21.2 / 27.6$
3FH	V7	V8

3) Typical Application Circuit

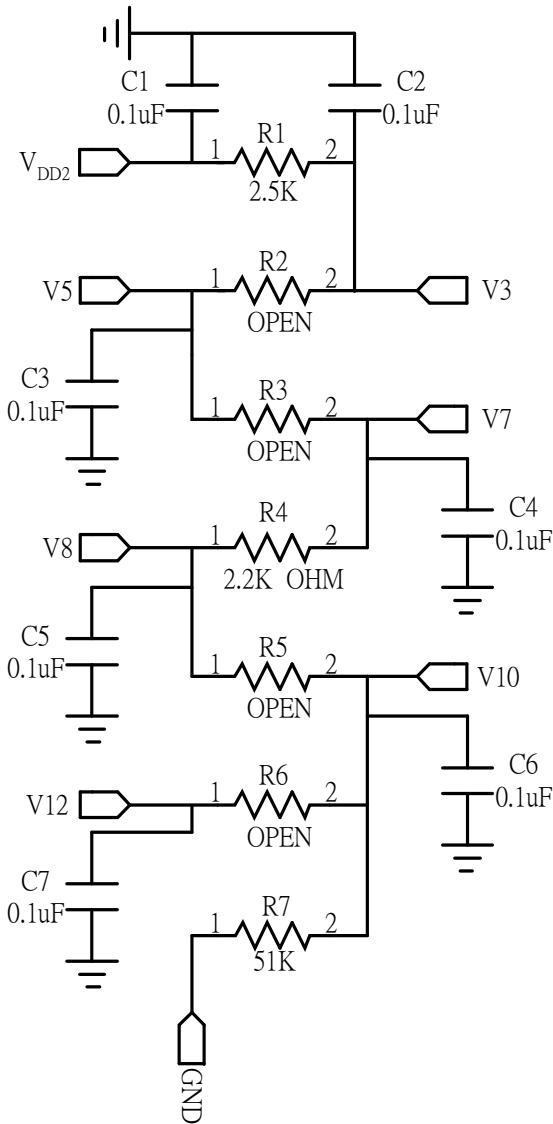

Note 5-6: When OE is connected to high “1”, the driver outputs are disabled (Gate output = V_{EE}). Under this condition, the operation of registers will not be affected.

Note 5-7: Select up or down shift

U/D	STVU	STVD	Shift
1	HiZ	Input	Down to Up
0	Input	HiZ	Up to Down

Note 5-8: Gate driver shift clock

Note 5-9: Gate on voltage, $V_{GG} = +17V$.

Note 5-10: Gate off voltage, $V_{EE} = -10V$.

Note 5-11: I_{LED} TYP.=20mA.

6. Absolute Maximum Ratings:
 $V_{SS1}=V_{SS2}=GND=0V, T_a=25^{\circ}C$

Parameters	Symbol	MIN.	MAX.	Unit	Remark
Supply Voltage	V_{DD1}	-0.3	2	V	
	V_{CC}	-0.3	5	V	
	V_{DD2}	-0.5	12.0	V	
	V_{GG}	-0.3	40.0	V	
	$V_{GG}-V_{EE}$	-	40.0	V	
	V_{EE}	-20	0.3	V	
Storage Temperature	T_{ST}	-20	+70	$^{\circ}C$	
Operating Temperature	T_{OP}	-20	+70	$^{\circ}C$	Notes 6-1

Notes 6-1 : Operating Temperature define that contrast, response time, other display optical character are $T_a=+25$.

7. Electrical Characteristics
7-1) Recommended Operating Conditions:
 $V_{SS1}=V_{SS2}=GND = 0V, T_a = 25^{\circ}C$

Item	Symbol	Min.	Typ.	Max.	Unit	Remark
Supply Voltage for Source Driver	V_{DD1}	3.0	3.3	3.6	V	
	V_{DD2}	9.5	10	10.5		
Supply Voltage for Gate Driver	V_{GG}	-	17	-	V	
	V_{EE}	-	-10	-	V	
	V_{CC}	3.0	3.3	3.6	V	
Digital Input Voltage	V_{IH}	$0.8V_{DD1}$	-	V_{DD1}	V	
	V_{IL}	0	-	$0.2V_{DD1}$	V	

7-2) Recommended driving condition for LED backlight
 $GND = 0V, T_a = 25^{\circ}C$

Parameter	Symbol	Min	TYP	MAX	Unit	Remark
Supply voltage of LED backlight	V_{LED}	9	9.6	11.4	V	$I_L = 20\text{ mA}$
Supply current of LED backlight	I_{LED1}		20		mA	Note 7-1
	I_{LED2}					
Backlight Power Consumption	P_{LED}	360	384	456	mW	Note 7-2

Note 7-1 : LED B/L applied information , please refer to the appendix at the end .

Note 7-2 : $P_{LED} = V_{LED} * I_{LED1} + V_{LED} * I_{LED2}$.

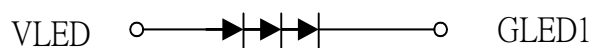

7-3) Power Consumption

Parameter	Symbol	Condition	Typ.	Max.	Unit	Remark
Supply Current for Gate Driver (Hi level)	I _{GG}	V _{GG} =+17V	0.12	0.15	mA	
Supply Current for Gate Driver (Low level)	I _{EE}	V _{EE} =-10V	0.15	0.19	mA	
Supply Current for Source Driver (Digital)	I _{DD1}	V _{DD1} =+3.3V	4.8	8.0	mA	
Supply Current for Source Driver (Analog)	I _{DD2}	V _{DD2} =+10V	16.0	30.0	mA	
Supply Current for Gate Driver (Digital)	I _{CC}	V _{CC} =+3.3V	0.17	0.21	mA	
LCD Panel Power Consumption			180	332	mW	
Backlight Power Consumption	P _{LED}		384	456	mW	
Total Power Consumption			564	788	mW	

8. Pixel Arrangement

The LCD module pixel arrangement is the stripe.

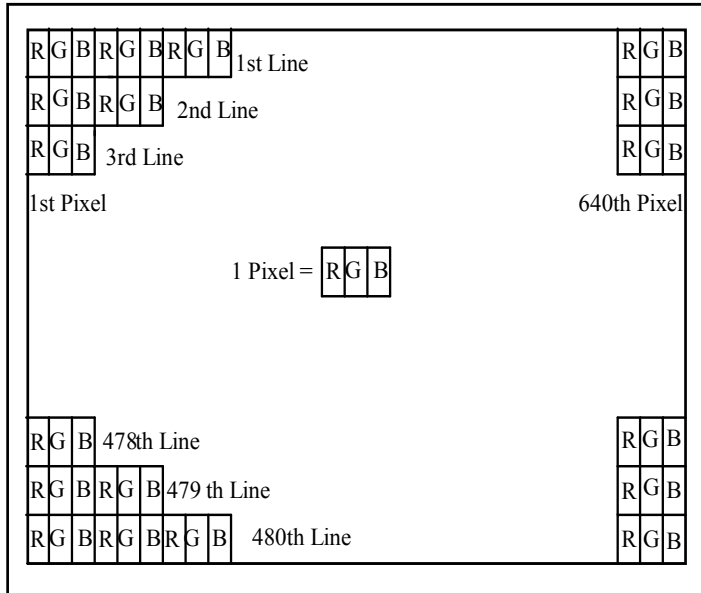

9. Display Color and Gray Scale Reference

Color		Input Color Data																	
		Red						Green						Blue					
		R5	R4	R3	R2	R1	R0	G5	G4	G3	G2	G1	G0	B5	B4	B3	B2	B1	B0
Basic Colors	Black	0	0	0	0	0	0	0	0	0	0	0	0	0	0	0	0	0	0
	Red (63)	1	1	1	1	1	1	0	0	0	0	0	0	0	0	0	0	0	0
	Green (63)	0	0	0	0	0	0	1	1	1	1	1	1	0	0	0	0	0	0
	Blue (63)	0	0	0	0	0	0	0	0	0	0	0	0	1	1	1	1	1	1
	Cyan	0	0	0	0	0	0	1	1	1	1	1	1	1	1	1	1	1	1
	Magenta	1	1	1	1	1	1	0	0	0	0	0	0	1	1	1	1	1	1
	Yellow	1	1	1	1	1	1	1	1	1	1	1	1	0	0	0	0	0	0
	White	1	1	1	1	1	1	1	1	1	1	1	1	1	1	1	1	1	1
Red	Red (00)	0	0	0	0	0	0	0	0	0	0	0	0	0	0	0	0	0	0
	Red (01)	0	0	0	0	0	1	0	0	0	0	0	0	0	0	0	0	0	0
	Red (02)	0	0	0	0	1	0	0	0	0	0	0	0	0	0	0	0	0	0
	Darker																		
	↓	↓	↓	↓	↓	↓	↓	↓	↓	↓	↓	↓	↓	↓	↓	↓	↓	↓	↓
	Brighter																		
	Red (61)	1	1	1	1	0	1	0	0	0	0	0	0	0	0	0	0	0	0
	Red (62)	1	1	1	1	1	0	0	0	0	0	0	0	0	0	0	0	0	0
	Red (63)	1	1	1	1	1	1	0	0	0	0	0	0	0	0	0	0	0	0
Green	Green (00)	0	0	0	0	0	0	0	0	0	0	0	0	0	0	0	0	0	0
	Green (01)	0	0	0	0	0	0	0	0	0	0	0	1	0	0	0	0	0	0
	Green (02)	0	0	0	0	0	0	0	0	0	0	1	0	0	0	0	0	0	0
	Darker																		
	↓	↓	↓	↓	↓	↓	↓	↓	↓	↓	↓	↓	↓	↓	↓	↓	↓	↓	↓
	Brighter																		
	Green (61)	0	0	0	0	0	0	1	1	1	1	0	1	0	0	0	0	0	0
	Green (62)	0	0	0	0	0	0	1	1	1	1	1	0	0	0	0	0	0	0
	Green (63)	0	0	0	0	0	0	1	1	1	1	1	1	0	0	0	0	0	0
Blue	Blue (00)	0	0	0	0	0	0	0	0	0	0	0	0	0	0	0	0	0	0
	Blue (01)	0	0	0	0	0	0	0	0	0	0	0	0	0	0	0	0	0	1
	Blue (02)	0	0	0	0	0	0	0	0	0	0	0	0	0	0	0	0	1	0
	Darker																		
	↓	↓	↓	↓	↓	↓	↓	↓	↓	↓	↓	↓	↓	↓	↓	↓	↓	↓	↓
	Brighter																		
	Blue (61)	0	0	0	0	0	0	0	0	0	0	0	0	1	1	1	1	0	1
	Blue (62)	0	0	0	0	0	0	0	0	0	0	0	0	1	1	1	1	1	0
	Blue (63)	0	0	0	0	0	0	0	0	0	0	0	0	1	1	1	1	1	1

10. Block Diagram

10-1) TFT-module Block Diagram

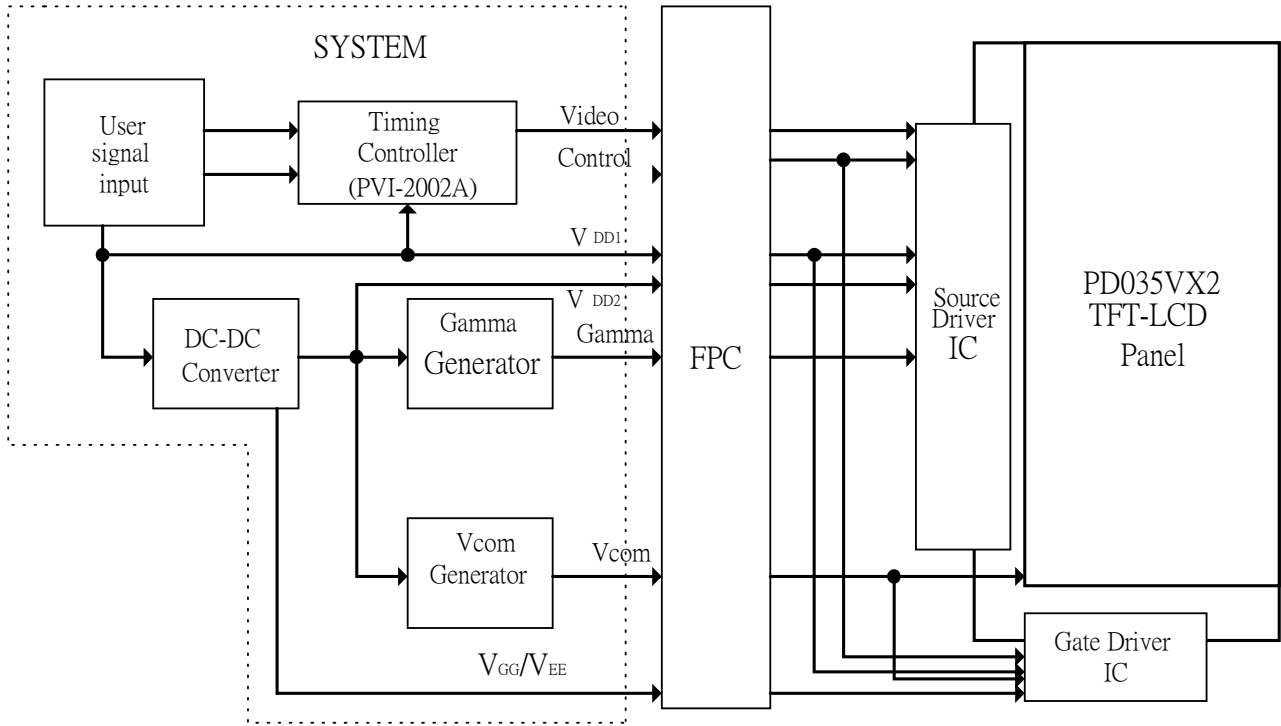

If you use PD035VX2, you must apply PVI-2002A(Timing controller) which Will generate signal to support PD035VX2.

11. Interface Timing
11.1) Timing Parameters

AC Electrical Characteristics ($V_{CC}=V_{DD1}=3.3V$, $V_{DD2}=10V$, $GND=V_{SS1}=V_{SS2}=0V$, $T_a=25^{\circ}C$)

Parameter	Symbol	Min.	Typ.	Max.	Unit
CLK Frequency	Fclk	-	25	40	MHz
CLK Pulse Width	T _{CPH}	25	-	-	ns
Data Set-up Time	T _{su}	4	-	-	ns
Data Hold Time	T _{hd}	2	-	-	ns
Propagation Delay of DIO2/1	T _{phl}	6	10	15	ns
Time That The Last Data to LD	T _{ld}	1	-	-	T _{CPH}
Pulse width of LD	T _{wld}	2	-	-	T _{CPH}
Time That LD to DIO1/2	T _{lds}	5	-	-	T _{CPH}
POL Set-up Time	T _{psu}	6	-	-	ns
POL Hold Time	T _{phd}	6	-	-	ns
OE Pulse Width	T _{OEV}	1	-	-	s
CKV Pulse Width	T _{CKV}	500	-	-	ns
STV Set-up Time	T _{SUV}	400	-	-	ns
STV Hold Time	T _{HDV}	400	-	-	ns
Horizontal Display Period	T _{HDP}	-	640	-	T _{CPH}
Horizontal Period Timing Range	T _{HP}	-	800	-	T _{CPH}
Horizontal Lines Per Field	T _V	520	525	640	T _{HP}
Vertical Display Timing Range	T _{DV}	-	480	-	T _{HP}

11.2) Timing Diagram

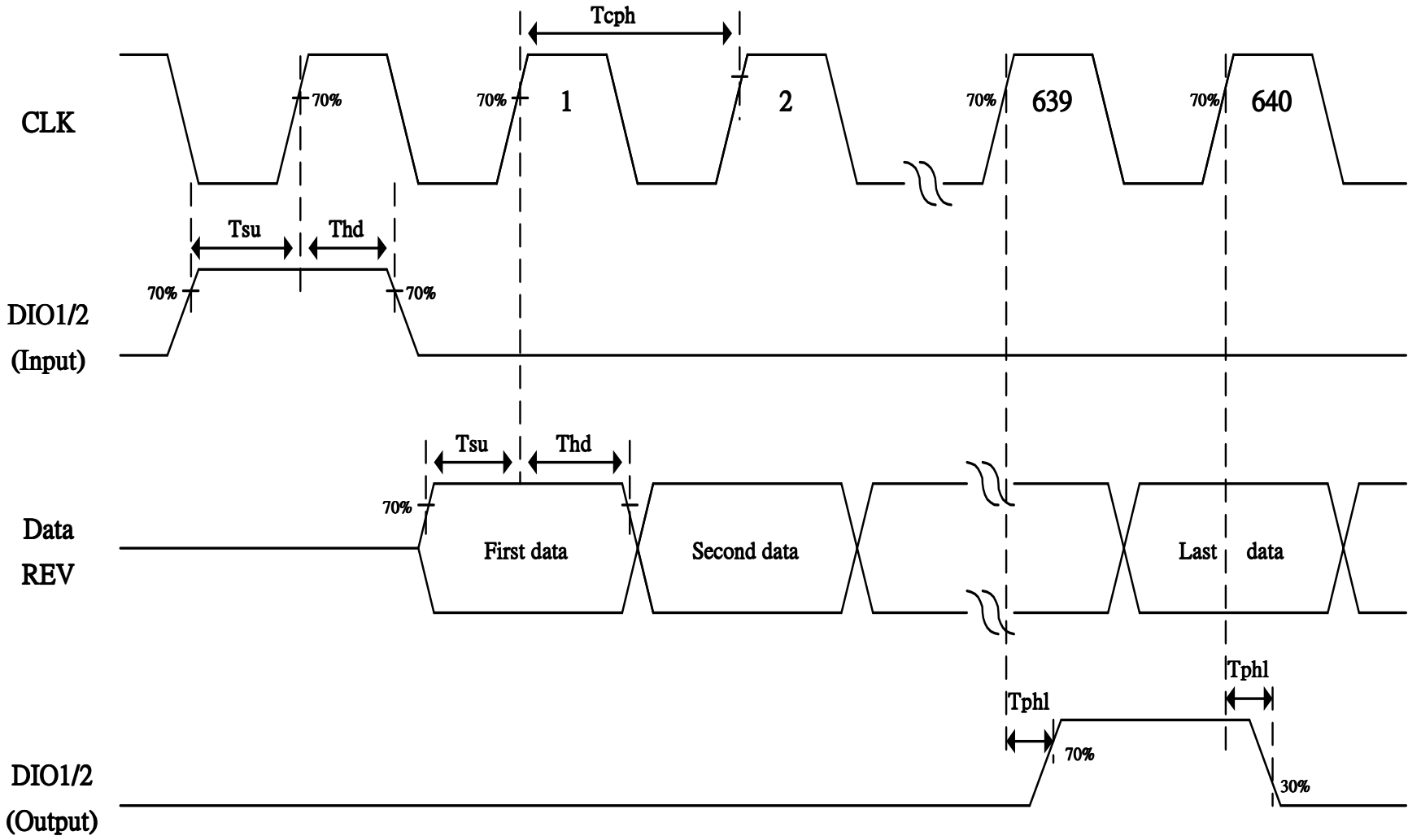

Fig. 11-1 Horizontal timing(1)

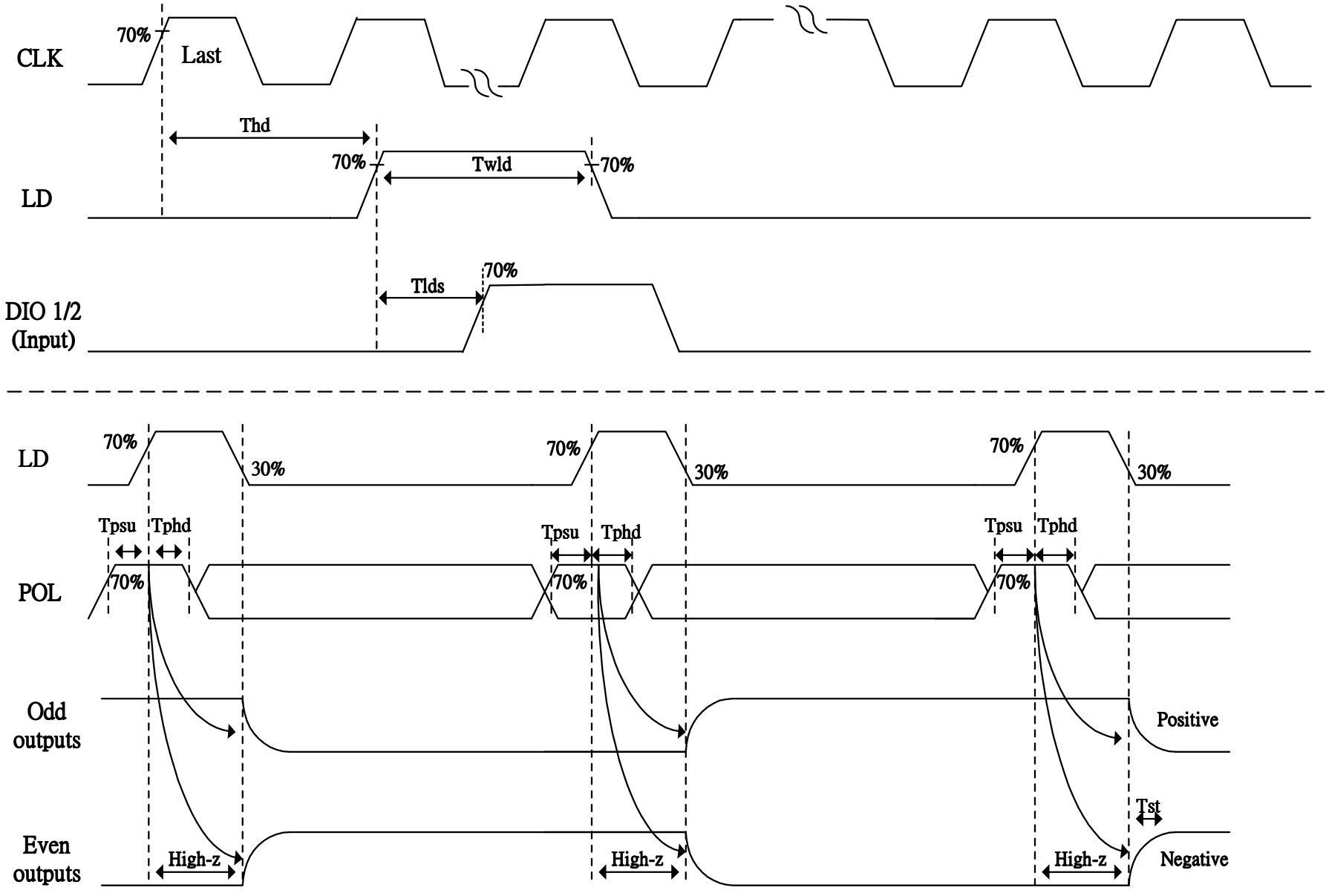

Fig. 11-2 Horizontal timing(2)

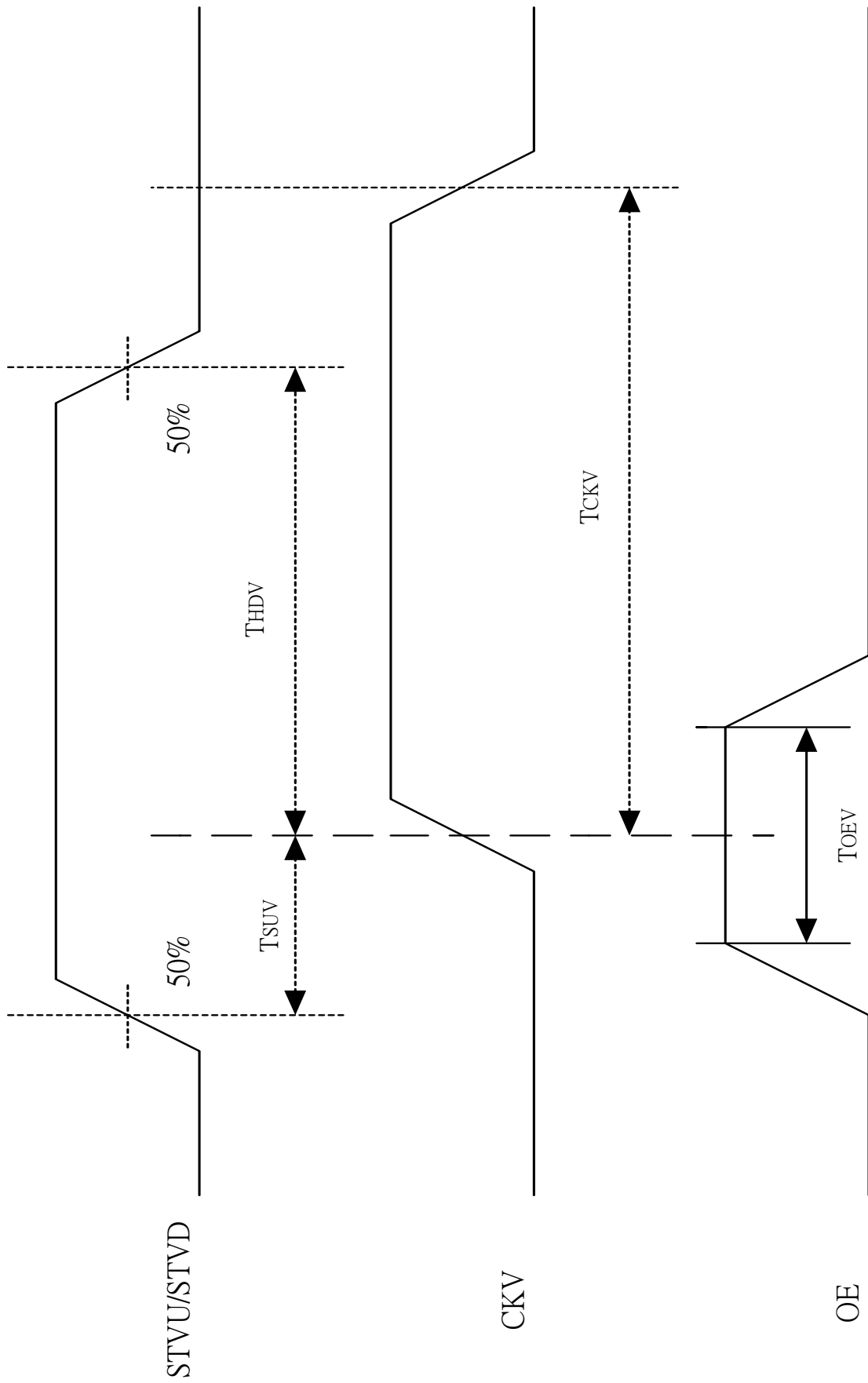

Fig. 11-3 Vertical shift clock timing

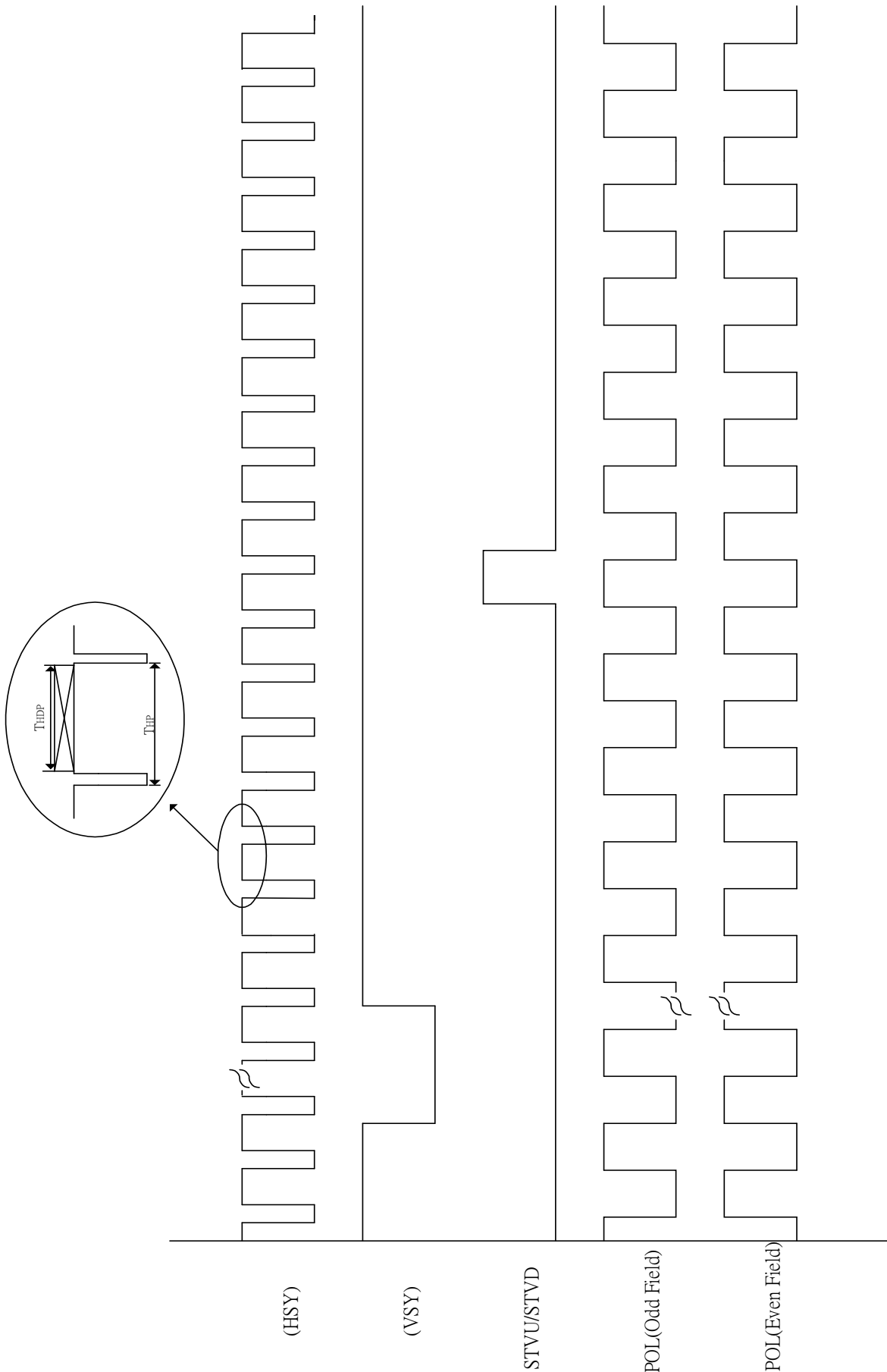
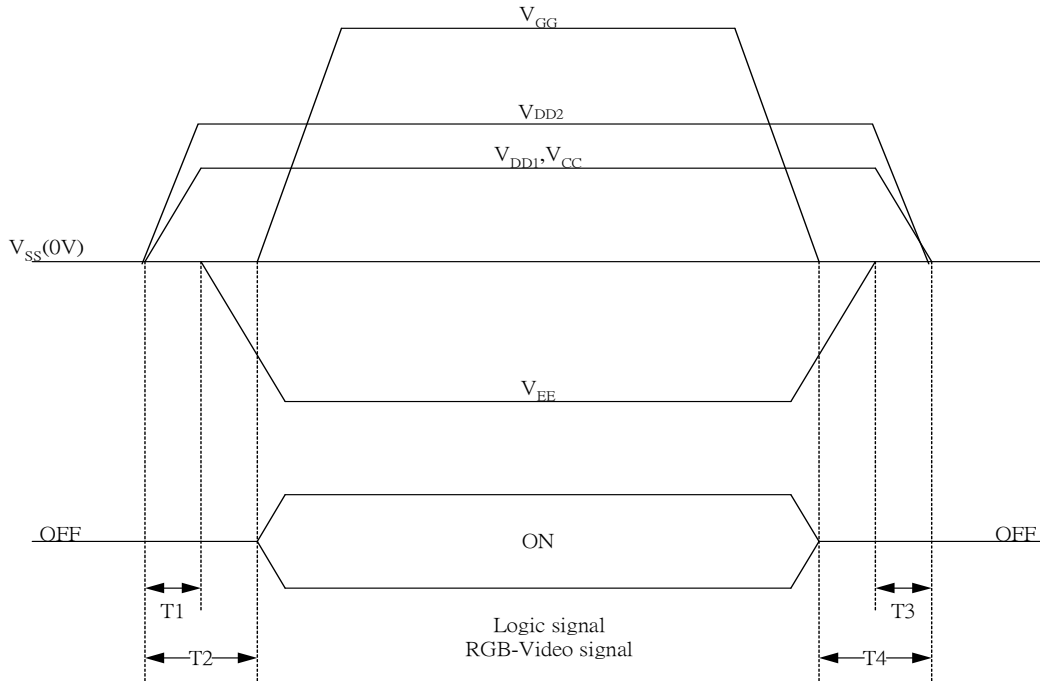

Fig. 11-4 Vertical timing

12. Power On Sequence



- 1. $10ms \leq T1 < T2$
- 1. $0ms < T3 \leq T4 \leq 10ms$

13. Optical Characteristics

13-1) Specification:

$T_a=25^\circ C$

Parameter		Symbol	Condition	MIN.	TYP.	MAX.	Unit	Remarks
Viewing Angle	Horizontal	θ	$CR > 10$	± 45	± 50		deg	Note 13-2
	Vertical	θ 12(to 12 o'clock)		10	15	-	deg	
		θ 11(to 6 o'clock)		30	35	-	deg	
Contrast Ratio		CR		200	400	-	-	Note 13-4
Response time	Rise	T_r	$\theta = 0^\circ$	-	15	30	ms	Note 13-3
	Fall	T_f		-	25	50	ms	
Brightness			$\theta = 0^\circ$	200	250		cd/m^2	Note 13-1
Uniformity		U	$\theta = 0^\circ$	70	75		%	Note 13-5
Cross Talk			$\theta = 0^\circ$	-	-	3	%	Note 13-6
White Chromaticity		x		0.28	0.31	0.34	-	Note 13-1
		y		0.30	0.33	0.36	-	
LED Life Time	$T_a=25^\circ C$			-	10000	-	hrs	

All the optical measurement shall be executed 1 minute after backlight being turn-on. The optical characteristics shall be measured in dark room (ambient illumination on panel surface less than 1 Lux). The measuring configuration shows as following figure.

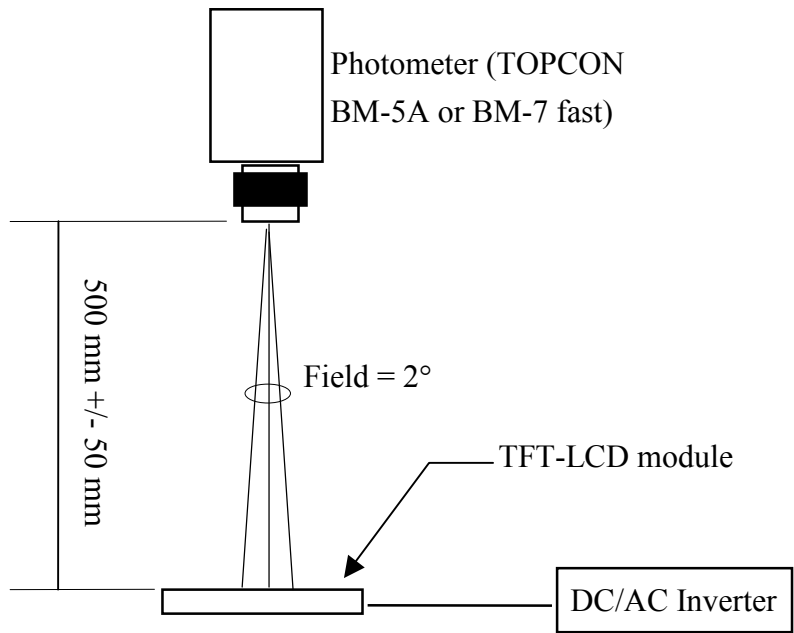

Optical characteristics measuring configuration

Note 13-1: 1. Topcon BM-5A or BM-7 fast luminance meter 1° field of view is used in the testing (after 1 minute operation).

Note 13-2: The definitions of viewing angles are as follow

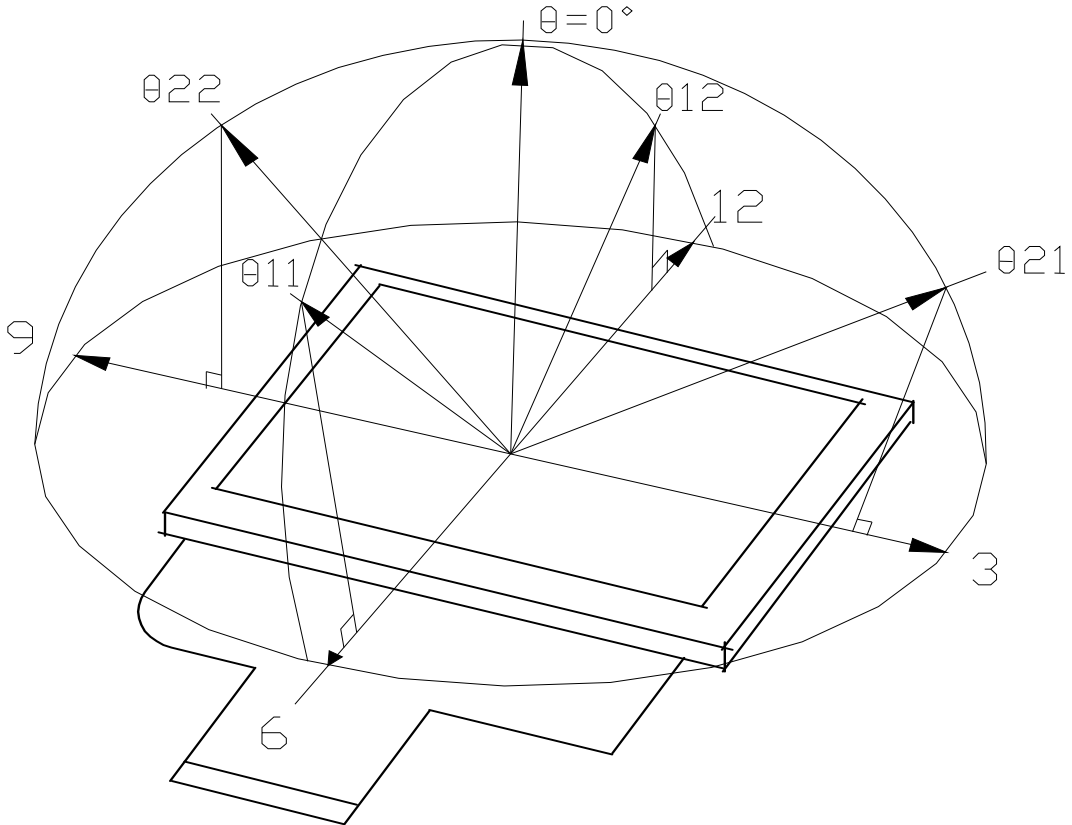

Note 13-3: Definition of Response Time T_r and T_f :

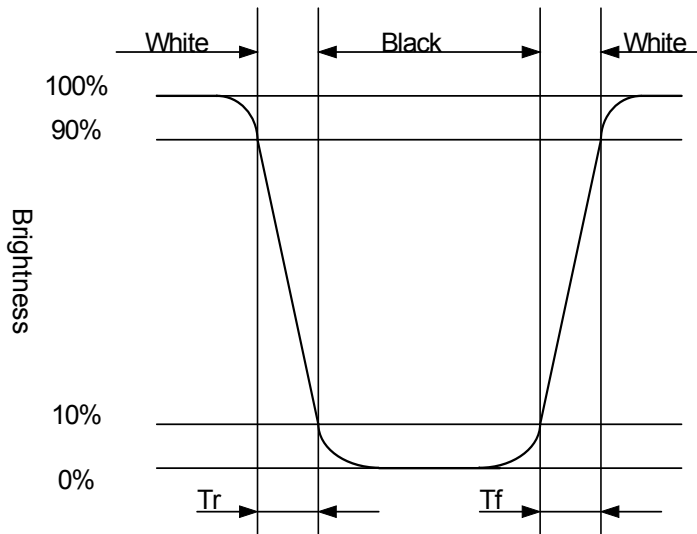

Note 13-4: The definition of contrast ratio $CR = \frac{\text{Luminance at gray level 63}}{\text{Luminance at gray level 0}}$

Note 13-5 : The uniformity of LCD is defined as

$$U = \frac{\text{The Minimum Brightness of the 9 testing Points}}{\text{The Maximum Brightness of the 9 testing Points}}$$

Luminance meter : BM-5A or BM-7 fast (TOPCON)

Measurement distance : 500 mm +/- 50 mm

Ambient illumination : < 1 Lux

Measuring direction : Perpendicular to the surface of module

The test pattern is white (Gray Level 63).

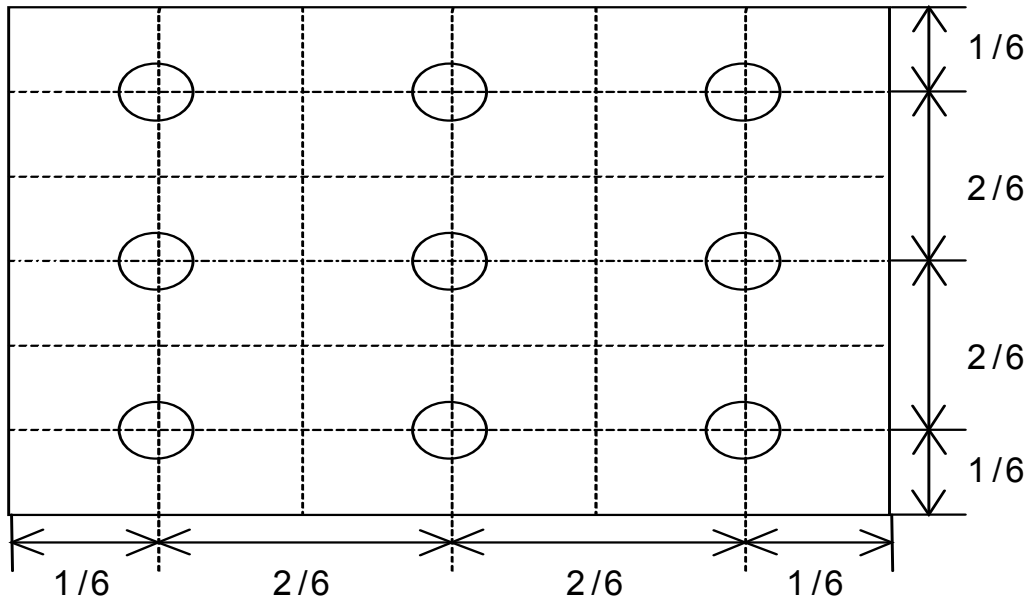

Note 13-6 : Cross Talk (CTK) = $\frac{|YA-YB|}{YA} \times 100\%$

YA : Brightness of Pattern A
 YB : Brightness of Pattern B
 Pattern A

(Gray Level 31)

Pattern B

(Gray Level 31, central
 black box exclusive)

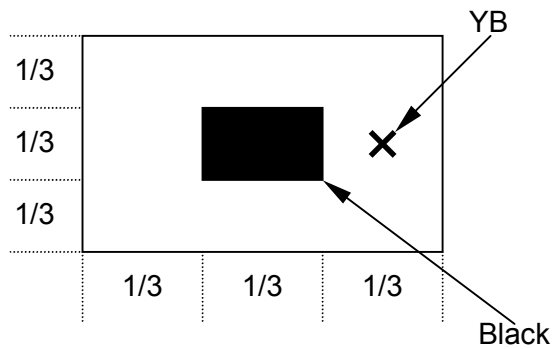
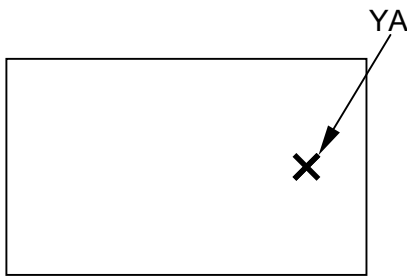

X: Testing Point (A and B are at the same point.)

(Gray Level 0)

14. Handling Cautions

14-1) Mounting of module

1. Please power off the module when you connect the input/output connector.
- b) Polarizer which is made of soft material and susceptible to flaw must be handled carefully.
- c) Protective film (Laminator) is applied on surface to protect it against scratches and dirt. It is recommended to peel off the laminator before use and taking care of static electricity.

14-2) Precautions in mounting

1. Wipe off water drops or finger grease immediately. Long contact with water may cause discoloration or spots.
- b) TFT-LCD module uses glass which breaks or cracks easily if dropped or bumped on hard surface. Please handle with care.
- c) Since CMOS LSI is used in the module. So take care of static electricity and earth yourself when handling.

14-3) Others

1. Do not expose the module to direct sunlight or intensive ultraviolet rays for many hours.
- b) Store the module at a room temperature place.
- c) The voltage of beginning electric discharge may over the normal voltage because of leakage current from approach conductor by to draw lump read lead line around.
- d) If LCD panel breaks, it is possibly that the liquid crystal escapes from the panel.
Avoid putting it into eyes or mouth. When liquid crystal sticks on hands, clothes or feet.
Wash it out immediately with soap.
- e) Observe all other precautionary requirements in handling general electronic components.

15. Reliability Test

No	Test Item	Test Condition
1	High Temperature Storage Test	Ta = +70°C, 240 hrs
2	Low Temperature Storage Test	Ta = -20°C, 240 hrs
3	High Temperature Operation Test	Ta = +70°C, 240 hrs
4	Low Temperature Operation Test	Ta = -20°C, 240 hrs
5	High Temperature & High Humidity Operation Test	Ta = +60°C, 90%RH, 240 hrs (No Condensation)
6	Thermal Cycling Test (non-operating)	-20°C → +70°C, 200 Cycles 30min 30min
7	Vibration Test (non-operating)	Frequency : 10 ~ 55 Hz Amplitude : 1.0 mm Sweep time : 11 mins Test Period : 6 Cycles for each direction of X, Y, Z
8	Shock Test (non-operating)	100G, 6ms Direction : ±X, ±Y, ±Z Cycle : 3 times
9	Electrostatic Discharge Test (non-operating)	200pF, 0Ω ±200V 1 time / each terminal

Ta: ambient temperature

Note : The protective film must be removed before temperature test.

[Judgement Criteria]

Under the display quality test conditions with normal operation state, there should be no change which may affect practical display function.

16. Packing

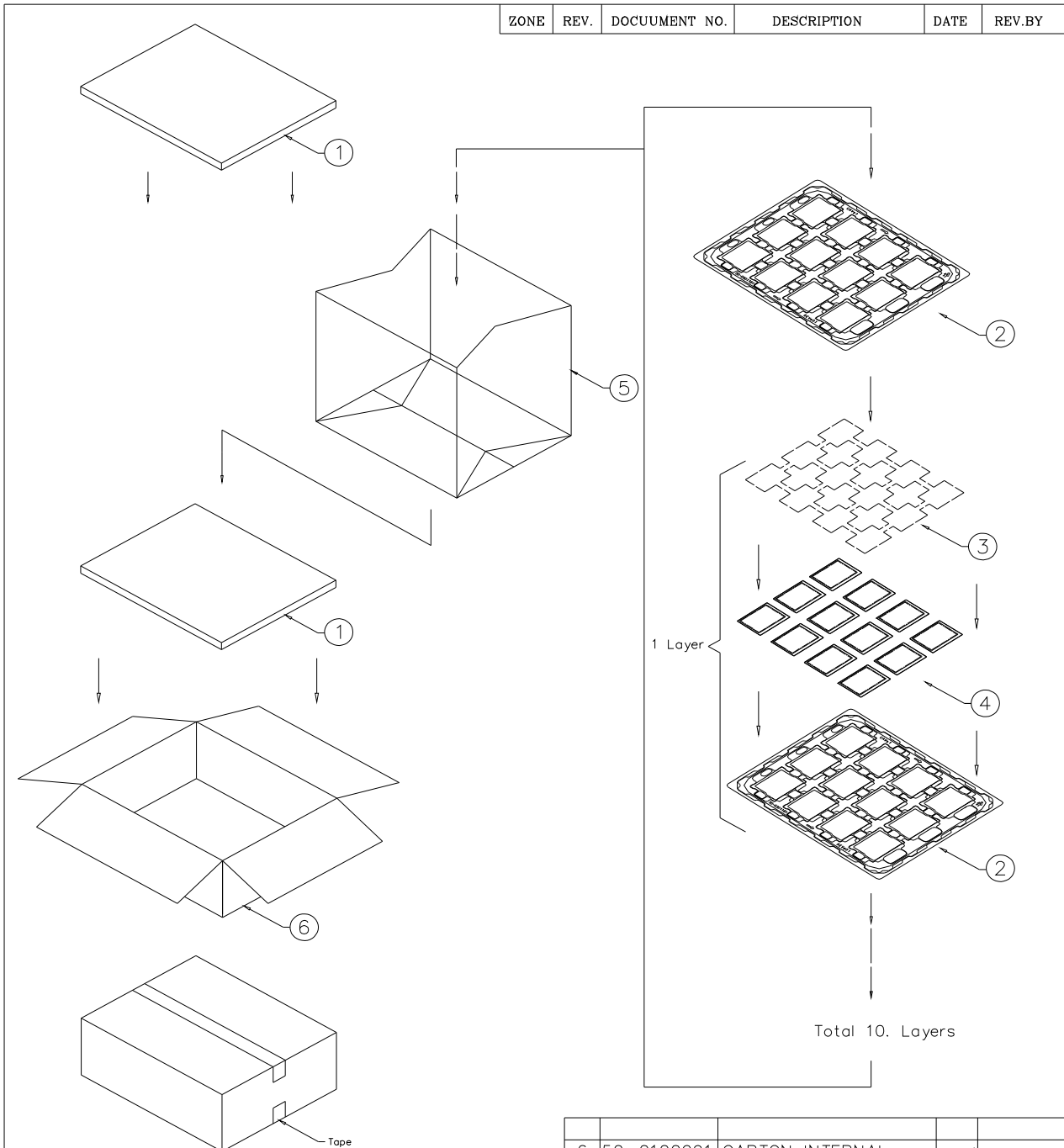

NOTE:

1. One layer include: 1 piece of cushion sheet, 12pcs panel & 1 piece of tray.
2. Q'TY: 120 pcs panel/carton.
3. Dimension: 455*375*190mm
4. Weight: 7.7 KG

ITEM	PART NO.	DESCRIPTION	QTY	REMARK
6	50-0100091	CARTON INTERNAL	1	
5	50-0500041	摺口袋450*380*700mm	1	抗靜電
4		PD035VX2	120	
3	50-0200059	EPE CUSHION SHEET	10	抗靜電
2	50-0301181	TRAY	11	抗靜電
1	50-0300491	EPE FOAM	2	

MTL.SPEC.		UNSPECIFIED TOL'S		REMARK		元太科技股份有限公司 Prime View International Co.,ltd.	
		ANGLE					
		ROUGHNESS					
APPROVE		SCALE	UNIT	SHEET	DWG.TITLE		
CHECK				1 OF 2	PA035VX2 PACKING Dim		
DESIGN	Dennis	MTL.NO.	'05.01.21		DWG.NO.	REV. 01	A4 SIZE

ZONE	REV.	DOCUMENT NO.	DESCRIPTION	DATE	REV. BY
------	------	--------------	-------------	------	---------

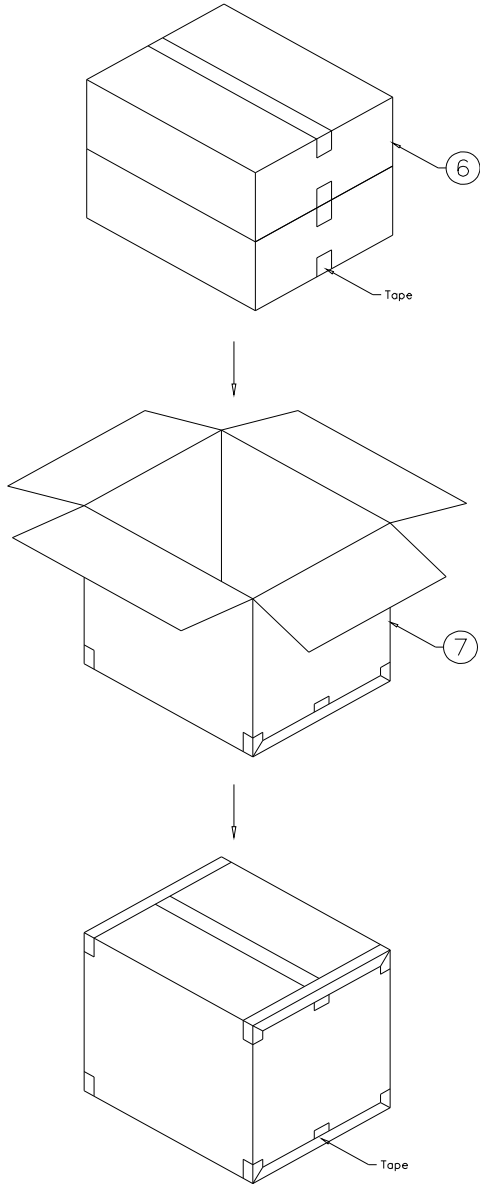
NOTE:

1. Q'TY: 240 pcs panel/carton.
2. Dimension: 480*396*405mm
3. Weight: 16.3 KG

ITEM	PART NO.	DESCRIPTION	QTY	REMARK
7	50-0100101	CARTON EXTERNAL	1	

MTL.SPEC.		UNSPECIFIED TOL'S		REMARK		 元太科技股份有限公司 Prime View International Co.,Ltd.	
		ANGLE					
		ROUGHNESS					
APPROVE		SCALE	UNIT	SHEET	DWG.TITLE		
CHECK				2 OF 2	PA035VX2 PACKING Dim		
DESIGN	Dennis	'05.01.21	MTL.NO.	DWG.NO.		REV.	A4 SIZE
						01	

Revision History

Rev.	Issued Date	Revised Contents
0.1	Oct. 21 , 2004	New
1.0	Jan. 26 , 2005	Removed Page 24 : Indication of Lot Number Label Add Page 24 : Reliability (Note : The protective film must be removed before temperature test.)
1.1	Apr. 20, 2005	Modify: Page10: Absolute Maximum Ratings - Operation Temperature range. Page24: Reliability Test Condition 1.Add High Temperature Operation Test +70°C. 2.Change Low Temperature Operation Test condition from 0°C to -20°C.

Appendix

